



# REFRIGERATION

SERVING THE FOOD INDUSTRY SINCE 1951

## 44-INCH CHEST FREEZER WITH SOLID FLAT TOP

Item: 46503 Model: FR-CN-0282

*Designed to merchandise and provide increased sales of frozen novelties and seasonal specialties*



- Perfect for convenience stores, ice cream shops, supermarkets, and/or restaurants
- Hinged lid design enables it to stay open while consumers are loading / taking out items without having to hold it up for hours

- Spacious to keep your frozen products in proper food storage temperature
- Pre-coated steel interior walls
- Fits maximum of 4 baskets



**WARRANTY**  
PARTS AND LABOR



Authorized Dealer

# REFRIGERATION

## 44-INCH CHEST FREEZER WITH SOLID FLAT TOP



### TECHNICAL SPECIFICATIONS

|                            |  |                        |                                   |
|----------------------------|--|------------------------|-----------------------------------|
| ITEM NUMBER                | 46503  | DEFROST                | Manual                            |
| MODEL                      | FR-CN-0282                                     | FOAMING COMPONENT      | Cyclopentane                      |
| CAPACITY (CU. FT.)         | 10 cu. ft.                                     | AMP                    | 2.2                               |
| POWER                      | 1/4 HP   | NEMA PLUG              | 5-15A                             |
| REFRIGERANT                | R600   | EXTERIOR MATERIAL      | Durable white powder coated steel |
| TEMPERATURE RANGE          | -22°C to -15°C / -8°F to 5°F                   | INTERIOR MATERIAL      | Precoated Steel                   |
| ELECTRICAL                 | 115V / 60Hz / 1Ph                              | DOOR PANEL             | Solid                             |
| NUMBER OF DOORS            | 1  | DOOR TYPE              | Hinged                            |
| NUMBER OF BASKETS INCLUDED | 1 (Fits maximum of 4 baskets, sold separately) | LOCK                   | No                                |
| EXTERIOR DIMENSIONS (WDH)  | 44" x 25 x 33.2"<br>1116 x 644 x 845 mm        | DEFROST DRAIN          | Yes                               |
| GROSS DIMENSIONS           | 45" x 25.9" x 34.6"<br>1148 x 660 x 880 mm     | INTERIOR LIGHT         | No                                |
| WEIGHT                     | 90 lbs. / 40.8 kg.                             | ADJUSTABLE THERMOSTAT  | Mechanical                        |
| GROSS WEIGHT               | 101 lbs. / 45.8 kg.                            | CASTERS (Front / Rear) | 2 rollers, 2 adjustable feet      |
|                            |  | CERTIFICATIONS         | ETL, ETL SANITATION               |

### TECHNICAL DRAWINGS WITH DETAILED DIMENSIONS

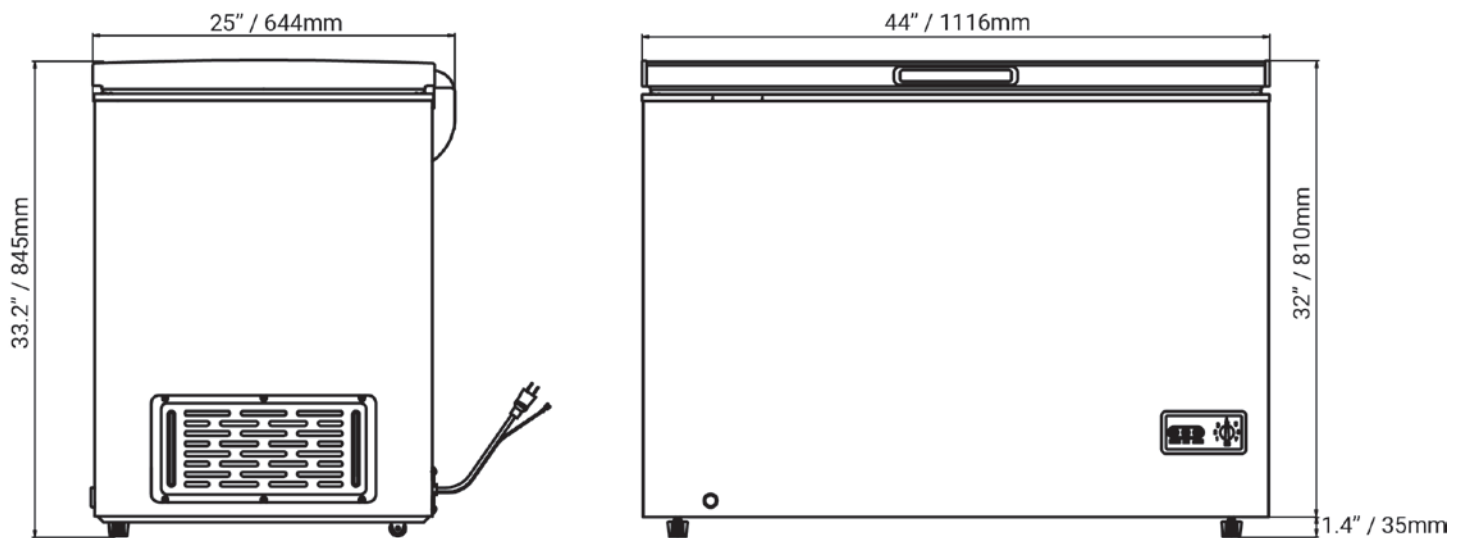

### OMCAN INC.

Telephone: 1-800-465-0234

Fax: (905) 607-0234

E-mail: [sales@omcan.com](mailto:sales@omcan.com)

Website: [www.omcan.com](http://www.omcan.com)



Follow us to keep up to date  
with the latest news and offers

